



A to Z Theatrical Supply and Service

800 East Meyer Boulevard

Kansas City, MO 64131

+1 (816) 523-1655

Greased Lightning User Manual

Thank you for considering A to Z Theatrical's *Greased Lightning* Prop Car. We have compiled this user manual to make the process as easy as possible. For the safety of the cast, crew and prop, please read these instructions fully before using *Greased Lightning*.

If you have any questions, please don't hesitate to contact us at (816) 523-1655 or via props@atoztheatrical.com

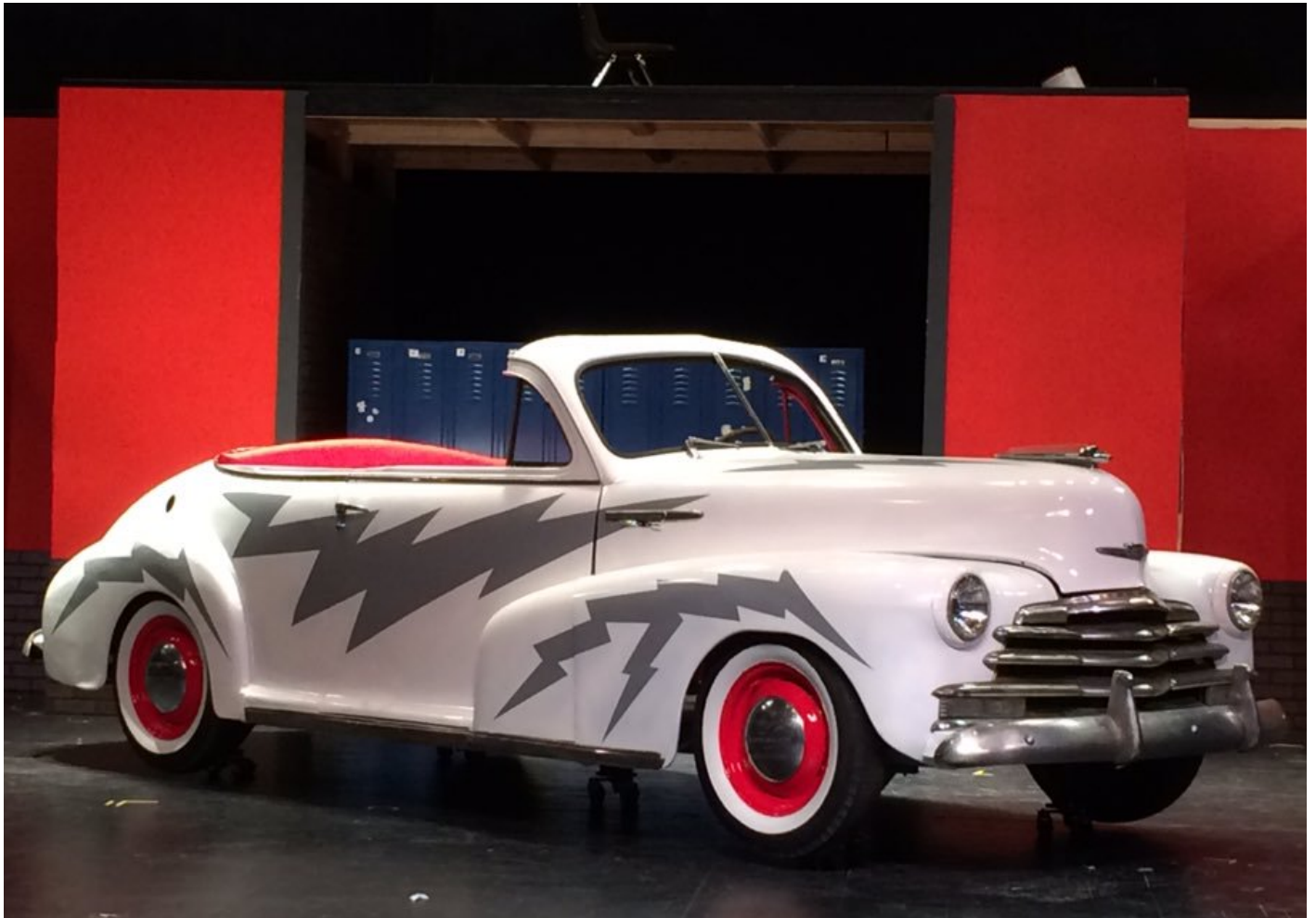



A to Z Theatrical Supply and Service

800 East Meyer Boulevard

Kansas City, MO 64131

+1 (816) 523-1655

Greased Lightning User Manual

Physical Specifications

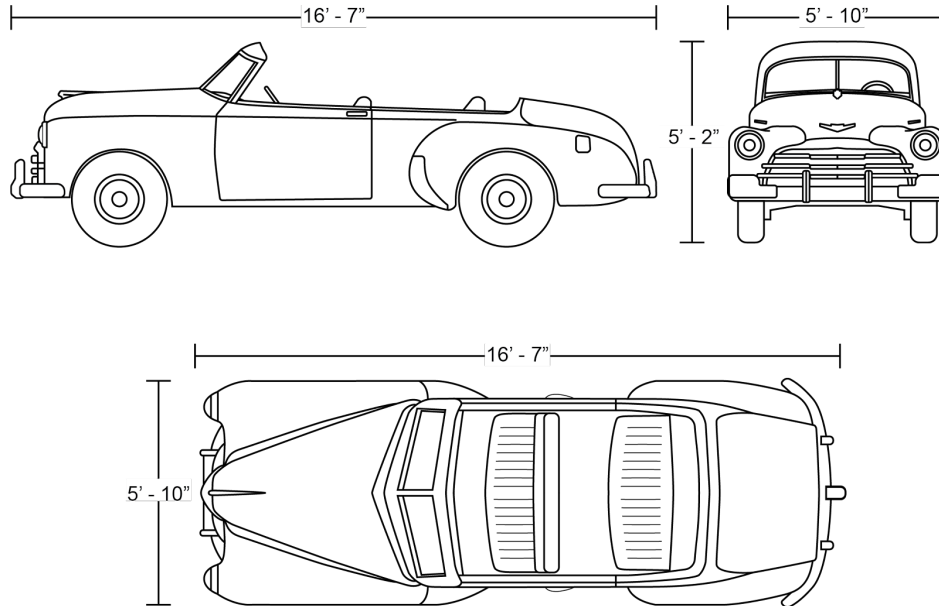

Width: 5'-10"

Length: 16'-7"

Height: 5'-2"

Weight: 1245 lbs **Capacity:** 5 performers (or ~800 pounds)

Parts List

1. Car
2. Detachable hood
3. Detachable 5th tri-swivel caster and its hardware
4. Car cover w/ ropes & hooks to attach
5. Steel "roll cage" w/ 1/4" bolts and bungee to attach for shipping

You Will Need:

A 7/16" socket or wrench to attach the center caster



A to Z Theatrical Supply and Service

800 East Meyer Boulevard

Kansas City, MO 64131

+1 (816) 523-1655

Greased Lightning User Manual

About The Prop

Greased Lightning is a 1947 Chevrolet Stylemaster Sport Sedan that has been modified for use on stage. The body, dashboard, steering wheel, hubcaps and engine components are all original to the car. The seats, upholstery and caster subframe system are custom built for theatrical use. This specific vehicle has been reconfigured into a convertible for easier lighting and visibility. A valve cover, air cleaner, and other engine elements are visible when the hood is removed, completing the presentation of the vehicle on stage as both a broken down jalopy and a polished hot rod.

The car is supported by five tri-swivel zero-throw casters which allowed Greased Lightning to be moved easily onstage when loaded with actors. If the vehicle suddenly rolls in an unusual fashion, check the casters. They likely have become tangled in foreign material that the car rolled over. Items like screws, loose tape, tie-line, and ribbons can all become trapped in the casters and cause them to stop working properly.



Greased Lightning, the day it arrived in our shop



A to Z Theatrical Supply and Service

800 East Meyer Boulevard

Kansas City, MO 64131

+1 (816) 523-1655

Greased Lightning User Manual

Using the Car

Every horizontal surface from the front bumper to the back seat is capable of supporting at least 200 pounds. This includes the hood, front and rear bumpers, which are reinforced for standing and dancing.

The car's trunk has not been reinforced and cannot support body weight.

Please take care when dancing or walking on the vehicle to wear only soft soled shoes. This minimizes the risk of scratching or chipping the car's paint. Be careful with any metal fasteners on costumes when sitting or sliding down the car: Rivets, buttons, or sequins may scratch the surface.

If any damage does occur during your run, please document it with photographs and let us know as soon as possible.

The car has two faces. The driver's side is unrestored for early scenes in the show before it gets repaired. With the hood removed, it can come onstage as the jalopy Kenickie pushes into the garage. To complete the conversion into Greased Lightning, have three performers or stagehands place the hood over the engine then rotate the car to reveal the restored passenger side with its hot rod paint job.

The Hood

The reinforcement in Greased Lightnings's hood makes it heavier than it appears. It should be placed by a minimum of three performers or stage hands, one at the front, and one on each side.

There are no latches or connectors to secure the hood, it is keyed onto the engine compartment and will remain in place even under vigorous dance conditions. It is strengthened to support a maximum of 200 pounds.



A to Z Theatrical Supply and Service

800 East Meyer Boulevard

Kansas City, MO 64131

+1 (816) 523-1655

Greased Lightning User Manual

Shipping & Preparation for Use

- When Greased Lightning arrives, it will be rolling on 4 of its 5 casters. The center caster is removed to make it possible to move the car up and down ramps. Once the car is past any ramps, install the center caster unit.
- The soft rubber tri-swivel casters shouldn't be pushed long distances across asphalt or rough concrete. They are intended for stage use. Rough surfaces will rapidly wear them down.
- The Center Caster mounts with four bolts under the center of the car. With 7/16" wrenches or socket set, attach the unit securely under the middle of the car with the provided bolts. You may need to use a jack to lift the car and provide access to install the caster.
- This fifth caster helps spread the weight of performers and makes the prop easier to maneuver. It must be in place to prevent issues with the car's performance.
- Once the caster is attached, give the prop a light dusting with a fine cloth and it is ready for use.

Preparation for Return Shipping

- Before packing the Greased Lightning for return shipping, take photographs of the prop from all directions to document its condition as it leaves your possession. Please send those photographs to props@atoztheatrical.com
- Make sure the hood is in place, and the trunk is closed and latched.
- Remove the Center caster, and repack it and its hardware as you received them.
- Secure the prop into the shipping vehicle with a ratchet strap to the tiedown point located behind each wheel. **Please do not secure directly to the wheels themselves.** Double check the security of all straps.



A to Z Theatrical Supply and Service

800 East Meyer Boulevard

Kansas City, MO 64131

+1 (816) 523-1655

Greased Lightning User Manual

- **The car must be loaded and shipped with the front of the prop car facing the rear of the transport. Failure to do so will incur an additional \$250 fee.**

***NOTE:** It is an advisable practice to document the condition of the prop when you unpack it and when you send it back. If anything happens during shipping or if there is damage you believe to have already occurred before it was sent to you, we need to know as soon as possible so that you are not billed for damage while it is in your possession. Should anything become damaged during your run, let us know immediately and we can advise towards your best solution.*

Acknowledgements & Contact

The Greased Lightning car was rebuilt and painted by the A to Z Theatrical production team. If you have any questions, suggestions, or issues regarding the prop or this manual, please contact us at (816) 523-1655. Reach us via email at props@atoztheatrical.com. We're also available for your costuming, prop, and scenic needs at www.atoztheatrical.com. Thank you for choosing A to Z Theatrical Supply & Service!