



# A to Z Theatrical Supply and Service

800 East Meyer Boulevard  
Kansas City, MO 64131  
+1 (816) 523-1655

## Hands on a Hardbody #2 User Manual

Thank you for considering A to Z Theatrical's *Hands On A Hardbody* Truck. We have compiled this user manual to make the process as easy as possible. For the safety of the cast, crew and prop, please read these instructions fully before using the prop. If you have any questions please contact us at (816) 523-1655 or email [hardbody@atoztheatrical.com](mailto:hardbody@atoztheatrical.com).

### PARTS LIST

1. Truck
2. Car Battery (located under the hood)
3. Battery Charger (Located under the hood) (Extension cord will be needed)
4. (2) Pneumatic Air Tanks (located where the passenger seat once was)

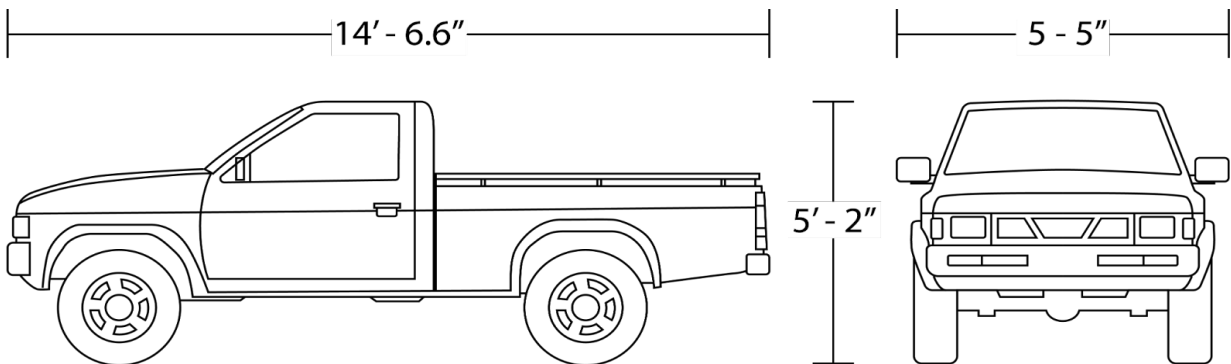

### Pneumatic Lifting System

The truck has tri-swivel casters on a pneumatic lift system. When the pneumatic system is engaged the truck lifts up so the tires are about 3/4 inch off of the ground. This feature allows the car to be moved easily, but is not necessary for all movements. The feature can be helpful when spinning the truck, or moving it in a non-standard forward or reverse motion. The steering and braking system is fully operational, and can be used with the pneumatic system if desired.

### Engaging the Pneumatic System

The lever is located behind the gas door, and must be held for the pneumatic system to remain engaged. Releasing the lever, will drop the truck immediately.





# A to Z Theatrical Supply and Service

800 East Meyer Boulevard  
Kansas City, MO 64131  
+1 (816) 523-1655

## Hands on a Hardbody #2 User Manual

### Pneumatic Air Tanks

There are (2) Air Tanks located where the passenger seat was removed. These air tanks should be charged to around 80 PSI for the beginning of the show to ensure there is enough pressurized air to last the show.



### Tailgate Installation/Removal

If, for whatever reason, you find yourself needing to remove the tailgate or it is off and it needs to be installed follow these steps for removal and install.

To remove the tailgate from the truck, lower the tailgate half ( $\frac{1}{2}$ ) way and loosen the tailgate straps by lifting them so that the larger part of the slip fit hole is over the pin. Rotate the tailgate so that it slips from the lower corner hinge channels. Lift carefully and never allow the outside (painted side not in the bed of the truck) to touch hard surfaces, to prevent scratching.

To install align the corner hinge channels and re attach the tailgate straps to the pins on the truck bed. be sure that the straps are at an angle that points the elbow towards the floor.

### Windows and Doors

All doors have handles and windows and locks. The locks are currently set to not lock but in the event that one does lock, the key is located in the ignition. Windows are not operational and are still the real glass on the truck (NOT PLEXY) and will shatter if improperly used. The windows are tinted to help cover up the lack of a passenger seat.

### Battery and Charger

Under the hood there is a car battery and charger. The red clip of the charger goes to the positive terminal and the black clip goes to the negative. There is an on and off switch on the charger, make sure it is in the OFF position when plugging in. You will need to use an extension cord to plug in the charger. **It is wise to run the charger when the truck is not in use to ensure a full charge during use.** Ideally you would run the cable from under the truck without opening the hood.

Lights and horn are operational with a charged battery. To turn lights on and off by using the lights switch, located to the right side of the steering wheel.





# A to Z Theatrical Supply and Service

800 East Meyer Boulevard  
Kansas City, MO 64131  
+1 (816) 523-1655

## Hands on a Hardbody #2 User Manual

### Weight Limits

Please do not exceed 375 lbs on the hood, top of the truck, and lined truck bed. This will ensure less damage to the truck over time.

### Costume Designer Notes

To protect the truck, A to Z suggests that any actor sitting or dancing on the truck be void of rivets on jeans or other hard items on costumes to prevent scratching.

### Paint

Incidental scratches happen during a rehearsal process or during performance. Be sure to call or email A to Z **before** fixing any scratches and document your work.

*\*The paint for this truck is Rustoleum High Performance Enamel 7564 Safety Red*



**NOTE:** *It is an advisable practice to document the condition of the prop when you unpack it and when you send it back. If anything happens during shipping or if there is damage you believe to have already occurred before it was sent to you, we need to know as soon as possible so that you are not billed for damage while it is in your possession. Should anything become damaged during your run, let us know immediately and we can advise towards your best solution.*

### Acknowledgements & Contact

The Hands on a Hardbody Truck was rebuilt and painted by the A to Z Theatrical production team. If you have any questions, suggestions, or issues about the prop or this manual please contact us at (816) 523-1655. Reach us via email at [hardbody@atoztheatrical.com](mailto:hardbody@atoztheatrical.com). We're also available for your costuming, prop, and scenic needs at [www.atoztheatrical.com](http://www.atoztheatrical.com).

Thank you for choosing A to Z Theatrical Supply & Service!