



A to Z Theatrical Supply and Service

800 East Meyer Boulevard

Kansas City, MO 64131

+1 (816) 523-1655

Hands on a Hardbody #1 User Manual

Thank you for considering A to Z Theatrical's *Hands On A Hardbody* Truck. We have compiled this user manual to make the process as easy as possible. For the safety of the cast, crew and prop, please read these instructions fully before using the prop. If you have any questions please contact us at (816) 523-1655 or email hardbody@atoztheatrical.com.

PARTS LIST

1. Truck
2. (4) Casters (Rear Casters come attached. Front casters may need to be mounted and can be found behind the driver's seat)
3. Car Battery (located under the hood)
4. Battery Charger (Located under the hood) (Extension cord will be needed)
5. (2) - 6" C- Clamps (Stored behind the seat)
6. (8) sets of bolts and nuts for front casters. ($\frac{3}{8}$ " x 1" hex bolts and nylon lock nuts)
7. Small bottle jack (Stored behind the seat)

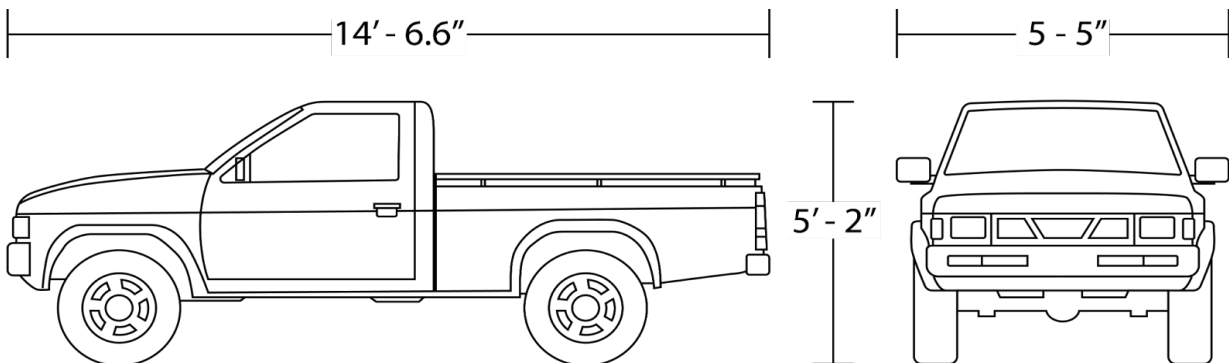

Front Caster Installation/Removal

There are two (2) brackets located along the front axle of the truck. Each bracket has a plate with four (4) $\frac{3}{8}$ " holes drilled. In the center of the truck there is a tube steel brace to use the car jack (**item #7**) to lift the front end enough to attach the casters (**#2**).

After securing the nuts and bolts to firmly hold the casters in place lower the truck gently using the car jack.

To remove casters use the car jack to raise the truck and remove nuts and bolts. Remove casters from under the truck and place them behind the driver's seat. Lower the truck gently using the jack. Return the jack to its position inside the truck.



A to Z Theatrical Supply and Service

800 East Meyer Boulevard

Kansas City, MO 64131

+1 (816) 523-1655

Hands on a Hardbody #1 User Manual

Rear Axle

The rear axle is fixed and will not move. Please leave the rear casters in place.

Front End Tire Rotation

The tires on the front of the truck will rotate unless clamped in place. This will not affect turning but does make using the tire/hub area to get on the truck tricky. Please use the c-clamps (#5) provided to lock onto the caliper and rotor of the wheel assembly as shown in the picture to the right.

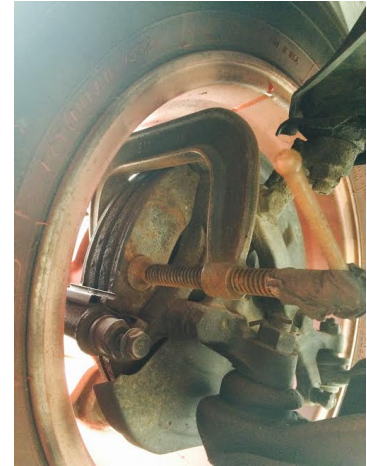

Tailgate Installation/Removal

If, for whatever reason, you find yourself needing to remove the tailgate or it is off and it needs to be installed follow these steps for removal and install.

To remove the tailgate from the truck, lower the tailgate half ($\frac{1}{2}$) way and loosen the tailgate straps by lifting them so that the larger part of the slip fit hole is over the pin. Rotate the tailgate so that it slips from the lower corner hinge channels. Lift carefully and never allow the outside (painted side not in the bed of the truck) to touch hard surfaces, to prevent scratching.

To install align the corner hinge channels and re attach the tailgate straps to the pins on the truck bed. be sure that the straps are at an angle that points the elbow towards the floor.

Windows and Doors

The doors have working handles, windows and locks. The locks are currently set to not lock but in the event that one does lock, the key is located in the ignition. There is also a spare in a hide-a-key box under the lip of the bed. Side windows are operational and are still the real glass, (NOT PLEXY!), and will shatter if improperly used.

Battery and Charger

Under the hood there is a car battery and charger. The red clip of the charger goes to the positive terminal and the black clip goes to the negative. There is an on and off switch on the charger, make sure it is in the OFF position when plugging in. You will need to use an extension cord to plug in the charger. **It is wise to charge the battery before or after each show to ensure a full charge during use.** Ideally you would run the cable from under the truck without opening the hood.



A to Z Theatrical Supply and Service

800 East Meyer Boulevard
Kansas City, MO 64131
+1 (816) 523-1655

Hands on a Hardbody #1 User Manual

Lights and horn are operational with a charged battery. To turn lights on and off use the lights button located above the center radio controls. If the driver's side window is rolled down, the switch can be accessed from outside the vehicle with the door closed.

Weight Limits

Please do not exceed 375lbs on the hood and top of the truck. This will ensure less damage to the truck over time.



Costume Designer Notes

To protect the truck, A to Z suggests that any actor sitting or dancing on the truck be void of rivets on jeans or other hard items on costumes to prevent scratching.

Paint

Incidental scratches happen during a rehearsal process or during performance. It's inevitable. Be sure to call or email A to Z **before** fixing any scratches and document your work.

**Paint color is to the right*



NOTE: *It is an advisable practice to document the condition of the prop when you unpack it and when you send it back. If anything happens during shipping or if there is damage you believe to have already occurred before it was sent to you, we need to know as soon as possible so that you are not billed for damage while it is in your possession. Should anything become damaged during your run, let us know immediately and we can advise towards your best solution.*

Acknowledgements & Contact

The Hands on a Hardbody Truck was rebuilt and painted by the A to Z Theatrical production team. If you have any questions, suggestions, or issues about the prop or this manual please contact us at (816) 523-1655. Reach us via email at hardbody@atoztheatrical.com. We're also available for your costuming, prop, and scenic needs at www.atoztheatrical.com.

Thank you for choosing A to Z Theatrical Supply & Service!